

AC SOLID STATE RELAY

KD20C10AX
KD20C15AX
KD20C25AX
KD20C40AX
KD20C50AX
KD20C75AX
KD20C90AX
KD20C100AX
KD20C125AX
KD20R125AX



KD SERIES

SPECIFICATIONS

MODEL NO.	CONTROL VOLTAGE RANGE	MUST TURN OFF VOLTAGE	INPUT IMPEDANCE	MAX LOAD CURRENT	LOAD VOLTAGE RANGE	MIN BLOCKING VOLTAGE	MAX OFF-STATE LEAKAGE	FREQUENCY RANGE	MAX 1-CYCLE PEAK SURGE
KD20C10AX	4 TO 32 VDC	MAX 1.0 VDC	1.5 Kohm	10A	24-280VAC	600VAC	LESS 7.5 mA	47-70HZ	100A
KD20C15AX	4 TO 32 VDC	MAX 1.0 VDC	1.5 Kohm	15A	24-280VAC	600VAC	LESS 7.5 mA	47-70HZ	160A
KD20C25AX	4 TO 32 VDC	MAX 1.0 VDC	1.5 Kohm	25A	24-280VAC	600VAC	LESS 7.5 mA	47-70HZ	260A
KD20C40AX	4 TO 32 VDC	MAX 1.0 VDC	1.5 Kohm	40A	24-280VAC	600VAC	LESS 7.5 mA	47-70HZ	400A
KD20C50AX	4 TO 32 VDC	MAX 1.0 VDC	1.5 Kohm	50A	24-280VAC	600VAC	LESS 7.5 mA	47-70HZ	500 A
KD20C75AX	4 TO 32 VDC	MAX 1.0 VDC	1.5 Kohm	75A	24-280VAC	600VAC	LESS 7.5 mA	47-70HZ	750 A
KD20C90AX	4 TO 32 VDC	MAX 1.0 VDC	1.5 Kohm	90A	24-280VAC	600VAC	LESS 7.5 mA	47-70HZ	900 A
KD20C100AX	4 TO 32 VDC	MAX 1.0 VDC	1.5 Kohm	100A	24-280VAC	600VAC	LESS 7.5 mA	47-70HZ	1000A
KD20C125AX	4 TO 32 VDC	MAX 1.0 VDC	1.5 Kohm	125A	24-280VAC	1200VAC	LESS 15 mA	47-70HZ	1250A
KD20R125AX	4 TO 32 VDC	MAX 1.0 VDC	1.5 Kohm	125A	24-280VAC	1200VAC	LESS 15 mA	47-70HZ	1250A

MODEL NO.	MAX OFF STATE dv/dt	MAX ON-STATE VOLTAGE DROP	ISOLATE IMPEDENCE	DIELECTRIC STRENGTH INPUT-OUTPUT	DIELECTRIC STRENGTH INPUT-OUTPUT-CASE	TURN ON TIME	TURN OFF TIME	CAPACITANCE IN-OUT	WEIGHT (g)
KD20C10AX	200 V/ μ SEC	2.0VACrms	10^9 ohm	4000 VACrms	2500 VAC (rms)	LESS 2 mSec	LESS 1/2 AC CYCLE	LESS 15 PF	95 g
KD20C15AX	200 V/ μ SEC	2.0VACrms	10^9 ohm	4000 VACrms	2500 VAC (rms)	LESS 2 mSec	LESS 1/2 AC CYCLE	LESS 15 PF	95 g
KD20C25AX	200 V/ μ SEC	2.0VACrms	10^9 ohm	4000 VACrms	2500 VAC (rms)	LESS 2 mSec	LESS 1/2 AC CYCLE	LESS 15 PF	100 g
KD20C40AX	200 V/ μ SEC	2.0VACrms	10^9 ohm	4000 VACrms	2500 VAC (rms)	LESS 2 mSec	LESS 1/2 AC CYCLE	LESS 15 PF	100 g
KD20C50AX	200 V/ μ SEC	2.0VACrms	10^9 ohm	4000 VACrms	2500 VAC (rms)	LESS 2 mSec	LESS 1/2 AC CYCLE	LESS 15 PF	100 g
KD20C75AX	200 V/ μ SEC	2.0VACrms	10^9 ohm	4000 VACrms	2500 VAC (rms)	LESS 2 mSec	LESS 1/2 AC CYCLE	LESS 15 PF	100 g
KD20C90AX	200 V/ μ SEC	2.0VACrms	10^9 ohm	4000 VACrms	2500 VAC (rms)	LESS 2 mSec	LESS 1/2 AC CYCLE	LESS 15 PF	100 g
KD20C100AX	200 V/ μ SEC	2.0VACrms	10^9 ohm	4000 VACrms	2500 VAC (rms)	LESS 2 mSec	LESS 1/2 AC CYCLE	LESS 15 PF	100 g
KD20C125AX	1000 V/ μ SEC	2.0VACrms	10^9 ohm	4000 VACrms	2500 VAC (rms)	LESS 2 mSec	LESS 1/2 AC CYCLE	LESS 15 PF	110 g
KD20R125AX	1000 V/ μ SEC	2.0VACrms	10^9 ohm	4000 VACrms	2500 VAC (rms)	LESS 2 mSec	LESS 1/2 AC CYCLE	LESS 15 PF	110 g

OUTLINE DIMENSIONS (unit:mm)

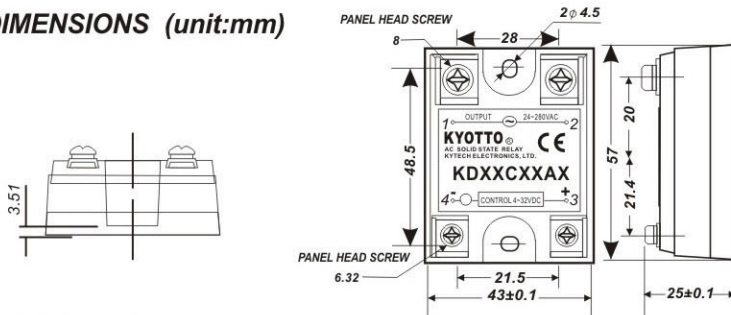

EQUIVALENT CIRCUIT

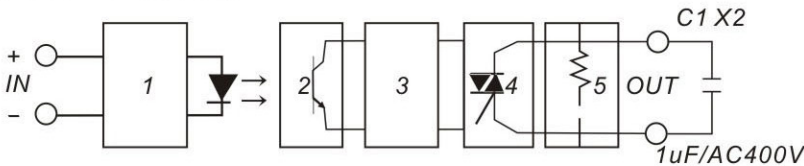

- 1.INPUT CIRCUIT
- 2.PHOTO DETECTOR
- 3.ZERO-CROSS CIRCUIT
- 4.OUTPUT CIRCUIT
- 5.PROTECTED CIRCUIT

CHARACTERISTIC CURVES

